



C O M M E R C I A L P L A S T I C S E A T S



1655C

Seats shall be No. _____ as manufactured by Bemis Manufacturing Co. Seats shall be extra heavy weight and injection molded of solid plastic. Seats shall be open front less cover for elongated bowl and feature large molded-in bumpers. External check hinges to feature 300 Series stainless steel posts that stop seat 11 degrees beyond vertical. Uses 300 Series stainless steel hardware. Color to be _____. (specify white or fixture manufacturer's color) Hinges shall be _____. (specify hinge type)



1655C External check hinge stops seat 11° beyond vertical.

1655SSC Stainless steel, self-sustaining and external check hinge holds seat in any raised position up to 11° beyond vertical.

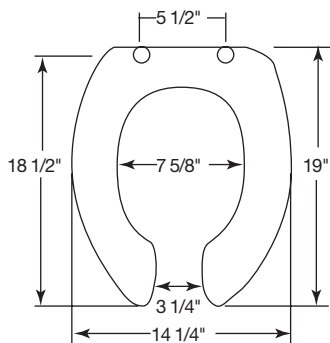

Ring thickness is 1"
Ring thickness including the bumper is 1-3/16"



EXTERNAL CHECK HINGES WITH 300 SERIES STAINLESS STEEL POST



EXTERNAL CHECK HINGE



1655C PROFILE

**** ANSI Z124.5 section 5.1.2 Tests have shown that this product will support weights up to 500 pounds.****
(Contact Bemis Mfg. Co., for test data)