



COMMERCIAL PLASTIC SEATS



1955C

Seats shall be No. _____ as manufactured by Bemis Manufacturing Co. Seats shall be heavy weight and injection-molded of solid plastic. Seats shall be open front less cover for elongated bowl and feature large molded-in bumpers. External check hinges to feature 300 Series stainless steel posts that stop seat 11 degrees beyond vertical. Uses 300 Series stainless steel hardware. Color to be _____. (specify white or fixture manufacturer's color) Hinges shall be _____. (specify hinge type)

1955C External check hinge stops seat 11° beyond vertical.

1955SSC Stainless steel, self-sustaining and external check hinge holds seat in any raised position up to 11° beyond vertical.

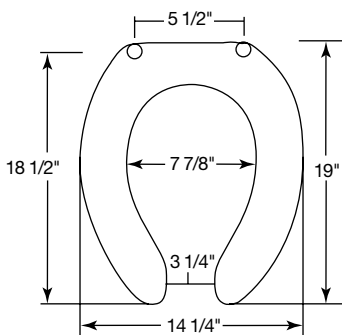

Ring thickness is 1"
Ring thickness including the bumper is 1-3/16"



CONCEALED CHECK HINGES WITH 300 SERIES STAINLESS STEEL POST



CONCEALED CHECK HINGE



CONTOURED SEAT