



PROLINE™/PROSEAT™ MOLDED WOOD SEATS



550PRO

Seats shall be 550PRO as manufactured by Bemis Manufacturing Co. Seats shall be molded wood, multi-coat enamel finish with open front and cover to fit round bowl. Color-matched bumpers and hinges. Hextite™ hinges with non-corrosive top-tightening bolts, wing nuts and no-slip washers. Color to be _____. (specify white or fixture manufacturer's color)

Bemis PROseats™ have a sleek design never before seen in a "wood" seat. PROseat™ color-matched components, Hextite™ hinges and a three-layer enamel finish provide guaranteed durability and satisfaction for the plumbing professional.

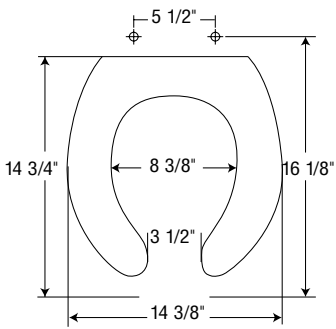

Ring thickness is 3/4"
Ring thickness including the bumper is 1-1/16"
Height of the seat with cover is 1-7/8"



TOP-TIGHTENING
HEXTITE™ HINGE



STURDY HEXTITE™ HINGE

